

INSTRUCTION MANUAL

NSW Schools / TAFE - ART 7900 Hand Spot Welder (240V) 2 kVA



K8433

TECNA[®]



	Art. 7900	PUNTATRICE CON TIMER INCORPORATO A SCR, SENZA REGOLAZIONE DI CORRENTE, CON COMPENSAZIONE, 2 kVA
I	Art. 7902-7902P	PUNTATRICE CON TIMER INCORPORATO A SCR, CON REGOLAZIONE DI CORRENTE, CON COMPENSAZIONE, 2.5 kVA
	Art. 7903-7903P	PUNTATRICE CON TIMER INCORPORATO A SCR, CON REGOLAZIONE DI CORRENTE, CON COMPENSAZIONE, 6 kVA, RAFFREDDATA AD ACQUA
	Item 7900	SPOT WELDER WITH BUILT-IN SCR TIMER WITHOUT CURRENT ADJUSTMENT, WITH COMPENSATION, 2 kVA
GB	Item 7902-7902P	SPOT WELDER WITH BUILT-IN SCR TIMER WITH CURRENT ADJUSTMENT, WITH COMPENSATION 2.5 kVA
	Item 7903-7903P	SPOT WELDER WITH BUILT-IN SCR TIMER WITH CURRENT ADJUSTMENT, WITH COMPENSATION, 6 kVA, WATER COOLED
	Art. 7900	PINCE A SOUDER AVEC TEMPORISATEUR INCORPORE A THYRISTORS, SANS REGLAGE DE COURANT, AVEC COMPENSATION, 2 kVA
F	Art. 7902-7902P	PINCE A SOUDER AVEC TEMPORISATEUR INCORPORE A THYRISTORS, AVEC REGLAGE DE COURANT ET COMPENSATION, 2.5 kVA
	Art. 7903-7903P	PINCE A SOUDER AVEC TEMPORISATEUR INCORPORE A THYRISTORS, AVEC REGLAGE DE COURANT ET COMPENSATION, 6 kVA, REFROIDIE PAR EAU
	Art. 7900	PUNKTSCHWEISSZANGE MIT EINGEBAUTEM THYRISTORGESTEUERTEM ZEITGEBER, OHNE STROMREGELUNG, MIT KOMPENSATION, 2 kVA
D	Art. 7902-7902P	PUNKTSCHWEISSZANGE MIT EINGEBAUTEM THYRISTORGESTEUERTEM ZEITGEBER, MIT STROMREGELUNG, MIT KOMPENSATION, 2.5 kVA
	Art. 7903-7903P	PUNKTSCHWEISSZANGE MIT EINGEBAUTEM THYRISTORGESTEUERTEM ZEITGEBER, MIT STROMREGELUNG, MIT KOMPENSATION, 6 kVA, WASSERGEKUHLT
	Art. 7900	PINZA DE SOLDADURA A PUNTOS PORTATIL CON TEMPORIZADOR INCORPORADO A TIRISTORES SIN REGLAJE DE CORRIENTE, CON COMPENSACION 2 kVA
E	Art. 7902-7902P	PINZA DE SOLDADURA A PUNTOS PORTATIL CON TEMPORIZADOR INCORPORADO A TIRISTORES CON REGLAJE DE CORRIENTE Y COMPENSACION 2.5 kVA
	Art. 7903-7903P	PINZA DE SOLDADURA A PUNTOS PORTATIL CON TEMPORIZADOR INCORPORADO A TIRISTORES CON REGLAJE DE CORRIENTE, CON COMPENSACION 6 KVA, REGRIGERADA POR AGUA

TECNA S.p.A. - Via Grieco 25/27 - 40024 Castel S. Pietro Terme - Bologna (Italia)			
Pho. +39.051.6954400 - Tel. +39.051.6954410 - Fax +39-051-6954490 - http://www.tecna.net			
DOCUMENTO NUMERO:		EDIZIONE:	FEBBRAIO 2007
DOCUMENT NUMBER:		EDITION:	FEBRUARY 2007
DOCUMENT NUMERO:	MAN2011	EDITION:	FÉVRIER 2007
DOKUMENT NUMMER:		AUSGABE:	FEBRUAR 2007
DOCUMENTO:		EDICION:	FEBRERO 2007
DISTRIBUTORE:			
DISTRIBUTOR:			
DISTRIBUTEUR:			
VERTRIEB:			
DISTRIBUIDOR:			

GB

INTRODUCTION

CAREFULLY READ THIS MANUAL BEFORE INSTALLING AND OPERATING WELDER.

The purpose of this instruction manual and of the enclosed documents is to transfer the necessary information for using the product in a proper and safe way. It includes pieces of information relevant to safety, installation, use, maintenance and disposal of the product.

This manual is addressed to the factory responsible in charge who must release it to the personnel in charge of the welder installation, use and maintenance. He/she must check that the information given in this manual and in the enclosed documents have been read and understood before operating on the welder. The manual must be stored in a well-known place, easy to reach, and must be looked up each time even little doubts should arise.

The welders marked with suffix P are equipped with the pulse functioning mode.

These welders must be installed in industrial environments for professional use only and are classified as class A resistance welding equipment. This product is foreseen for being used neither in domestic environment nor on low voltage public supply mains supplying domestic buildings. This may cause radiofrequency interferences.

All modifications, even slight ones, are forbidden because they could compromise the machine's safety and should invalidate both the welder EC certification and warranty. The welder has been designed for resistance spot welding of both ferrous and not ferrous (stainless steel, brass) materials. The welder must not be used for other application.

TECNA S.p.A is not responsible for any damage to both people, animals, things and to the welder itself caused by either a wrong use or the lack of the superficial observance of the safety warnings stated on this manual, nor it is responsible for damages coming from even slight tampering or from the use of not-suitable spare parts, or of spare parts other than the original ones.

Only for EU countries:



In accordance with European Directive 2002/96/EC for waste electrical and electronic equipment (WEEE), the presence of this symbol indicates that the product shall not be disposed of as urban waste. A separate collection must be arranged for.

It is the user's responsibility to dispose of this product correctly. They should contact their local authority or retailer.

The unlawful disposal of these wastes is punished with sanctions.

The correct disposal helps to optimize the recovery, the recycling and the reclaim of any materials and also reduces potential negative consequences for the environment and human health.

STANDARD ACCESSORIES

The welder is supplied equipped with:

N° 1 Allen key 5 mm.

N° 1 additional handle.

N° 1 electrode sharpener Ø10 (only items 7900).

N° 1 electrode sharpener Ø12 (only items 7902).

N° 1 pair of arms item 7501 L=125 mm (only items 7900).

N° 1 pair of arms item 7401 L=125 mm (only items 7902).

N° 1 instruction manual.

Item 7903 does not include the arms which must be ordered separately (see the accessories paragraph, page 36).

TECHNICAL FEATURES

Spot welder type		7900	7902	7903
Synchronous timer with SCR		•	•	•
Time adjustment	cycles	2+65	2+65	2+65
Current adjustment 40÷100%		-	•	•
Cooling		Air	Air	Water
Mains supply 50 Hz *	V	400	400	400
Nominal power at 50%	kVA	2	2.5	6
Max. welding power	kVA	13	16	16
Max. short circuit current	kA	7.2	8.2	8.2
with arms L=	mm	125	125	125
Thermal current at 100%	A	610	700	1700
Secondary no load voltage	V	2.3	2.5	2.5
Insulation class		F	F	F
Cooling water quantity	l/h	-	-	150
Max. water pressure	bar	-	-	2.5
Max. force on electrodes	daN	120	120	120
with arms L=	mm	125	125	125
Standard arms throat depth L	mm	125	125	-
Arms gap	mm	96	94	94
Max. electrodes stroke	mm	55	55	70
with arms L=	mm	125	125	150
Weight with arms 125 mm	kg	10.5	11	-
Weight with arms 150 mm	kg	-	-	12
Weight with arms 500 mm	kg	13	13.5	13.6
Aerial noise	dB(A)	< 70	< 70	< 70
Level of vibrations	m/s ²	< 2.5	< 2.5	< 2.5
Measurement conditions:				
welding time (cycles)		14	14	20
welding current (kA)		5	5	6
working rating (welds/min)		2	2	6

* Different voltages and frequency available on request

INSTALLATION

On receipt of the welder, verify the perfect integrity of the outer package; communicate to a responsible in charge possible anomalies which should be noticed. Possible damages on the outer package should arise some doubts on the integrity of its content. Remove the package and visually verify the welder integrity. Check that the welder is equipped with all the standard components; immediately inform the manufacturer in case some components should lack. All the material forming the package must be removed according to the present environmental protection regulations.

ELECTRICAL INSTALLATION

The welders described in this instruction manual have been designed for being used only for a professional purpose in an industrial environment and are classified as class A resistance welding equipment. **WARNING:** the class A resistance welding equipment are not foreseen for being used on low voltage public mains supplying domestic environments. This may cause radiofrequency interferences.

Installation must be carried out by specialised personnel only, aware of all safety rules. As this unit can be supplied for different power supply versions, before connecting the unit to the power line, check if the voltage shown on the features plate corresponds to the one of your power supply.

Consult table 5 to determine the capacity of the plug which must be installed on the supply cable; all use without plug is forbidden. The supply cables are brown and light blue, the earth cable is yellow / green.

It is compulsory to connect the welder to the protection conductor (earth). Verify that the protection conductor of the equipment is efficient and corresponds to the law in force.

The cables section to be used according to their length is stated on table 5. Examples of mains connections are shown on figure 6; the solution assuring the best safety is that with a residual current circuit breaker (RCCB). On the contrary, install fuses of the type stated on table 5.

COOLING CIRCUIT INSTALLATION (ONLY ITEMS 7903-7903P)

For a correct cooling of the welder it is necessary 150 l/h clean water at a maximum temperature of 30°C. When connecting the unit to the water line check for dirt or packing scraps in the hoses and connect the supply to the inlet G, and the drain to the outlet H, this to allow that still cool water immediately reaches the parts of the welder most subject to heating.

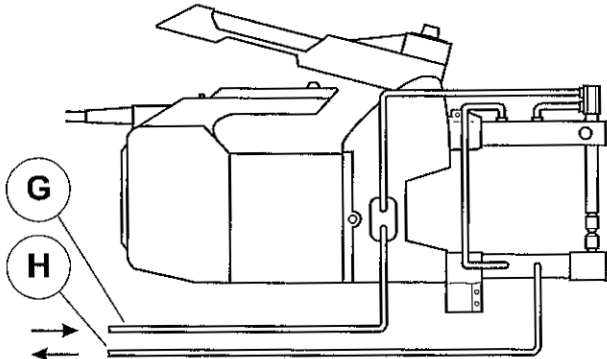

Water-cooling may be carried out by the following methods: with mains water supply, with re-circulating water, with heat exchanger (air-water) or with refrigerator. When working in high humidity with mains water supply or refrigerator, avoid the use of water at a low temperature in order to prevent moisture being produced inside the machine. In presence of hard water it is necessary to install a water softener in the inlet hose, this to avoid that deposits obstruct or reduce the water channels in the welder causing damages. If the machine is operated in a re-circulating water supply, the water softener must be placed on the supply of the tank for cooling water.

USE OF THE EQUIPMENT

Before connecting the unit to the power supply, check if the welder voltage corresponds to your mains voltage, as well as that both the power socket and system are in a good condition, and that the mains cable section is of the correct size (see table 5).

Check that the required performance is within the values stated on table 3 and 4.

Before starting work, carry out the following adjustments:

- 1 - Set up the arms and electrodes.
- 2 - Adjust the electrodes force.
- 3 - Set the welding parameters.

The following paragraphs better describe the above stated adjustments.

Before starting working, check that all safety warnings have read and understood.

The push-button (53) activating the timer and supplying the welding current is activated by closing the electrode by means of control lever (25).

Release the electrodes 0,2"-0,8" after the welding current has stopped; this delay improves the weld quality.

Electrodes must not be used to force the clamping of the pieces to weld.

Always monitor the electrodes which must always be clean, without any deformation. The truncated electrodes must have the proper diameter according to the work to be carried out.

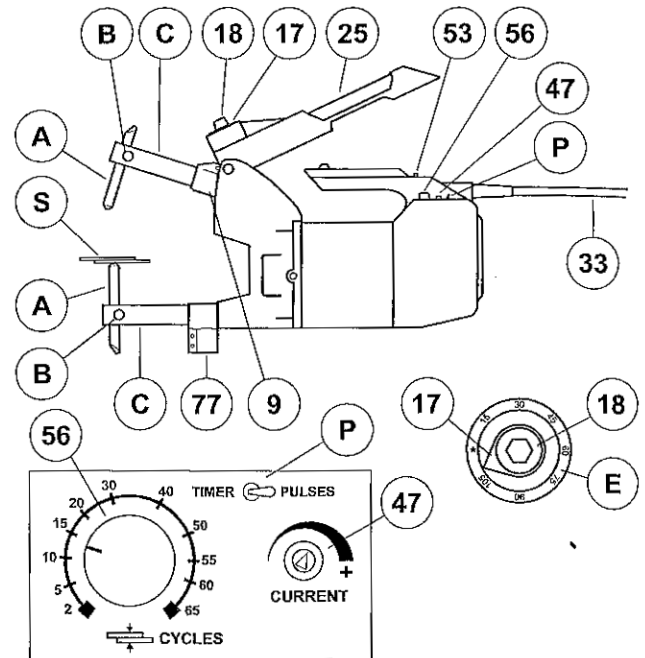

- A Electrodes
- B Electrode-locking
- C Arms
- E Electrode force scale
- P Timer-pulses selector (for versions P only)
- 9 Movable arm holder
- 17 Electrode force index
- 18 Electrode force adjustment
- 25 Electrode force lever
- 33 Mains cable
- 47 Welding current adjustment (only items 7902-7903)
- 53 Welding start push-button
- 56 Welding time adjustment
- 77 Fixed arm holder

Before starting the welding process, check the welding parameters (time, pressure, etc.). Use two off-cuts of the sheet to be welded; the spot is correct when the pulling test causes the coming out of the welding nugget with the hole of a sheet. The twist test shows a pure area without porosity (see fig. 5).

When the work is over, disconnect the welder from the mains supply.

Never carry the welder by its cord or yank it to take it off from the socket. Keep the cord away from heat, oil and sharp edges.

Items 7903-7903P only.

The cooling water must circulate for some minutes after the welding cycle has been accomplished, so to enable the welder cooling. Never let the cooling circuit open if the machine is not used, so to avoid both leakage and the forming of moisture.

ADJUSTMENTS

Arms and electrodes set up.

With electrodes A clamping the pieces, the arms C should be parallel and the electrode tips must combine (fig. 1). To adjust them slacken the locking pin B, shift the electrode A, and block again. If it is necessary, pull out the arms for 6 mm. maximum (fig.2).

To disassemble and adjust the electrodes slacken locking pin B screw on arms with electrodes \varnothing 12 (range 74XX); hit the pin by means of a slight hammer stroke for electrodes \varnothing 10 (range 75XX). On water cooled arms, to disassemble electrodes use a key.

The electrode tip can have two different shapes according to the work to be carried out:

DOMED TIP

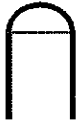

With this shape, it is not necessary to match the electrodes to the piece to be welded and maintenance is easier and quicker. The sharpener supplied as standard (range 7900-7902 only) will quickly restore to good condition the electrodes. The sharpener should be used on a drill at a speed of 300-600 rpm.

The dome tip electrodes are not suitable for use on arms longer than 250 mm.

TRUNCATED TIP



With this shape it is possible to have a better quality. The truncated tip reduces the electrodes impression on the sheets. The contact diameter of the electrodes must be suitable to the thickness of the sheet itself (see tab. 2). If the workpieces have different thickness, the contact diameter of each electrode is related to the thickness of the sheet it is in contact with (fig. 4). The diameters of the electrodes tips shown in table 2 must not be exceeded as this could cause overheating and poor welds. The truncated tip can be made out of the dome one by means of a file positioned between the electrodes (see fig. 3).

The electrodes on the water-cooled arms must always have the truncated tip.

Before starting welding it is always advisable to dress electrodes with a fine file or emery paper.

When using the truncated tip, best results are achieved by wrapping emery paper around a support of the same thickness as the sheets to be welded.

Electrode force adjustment

The welder is equipped with a force adjustment system allowing to know the set value. Before adjusting, it is necessary to set to zero the force indicator according to the following instructions:

- 1) Disconnect the welder from the mains supply.

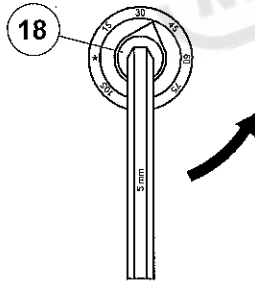

- 2) Slacken screw 18 by means of 5 mm Allen key.

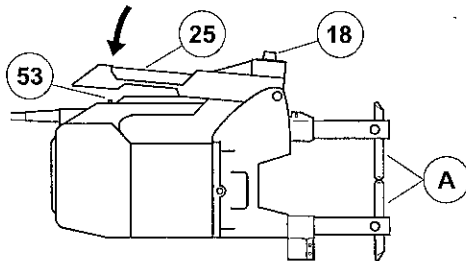

- 3) Press down lever (25) until push-button (53) is activated.

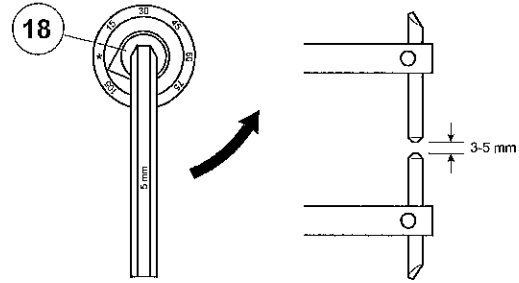

- 4) Slacken screw (18) until electrodes (A) are apart one from the other a few mm.

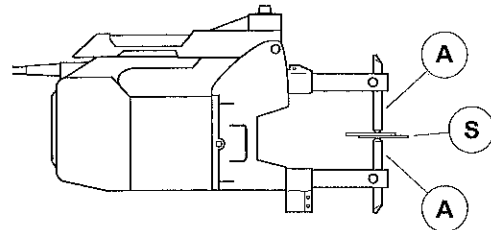

- 5) Place sheets (S) to be welded between electrodes (A).

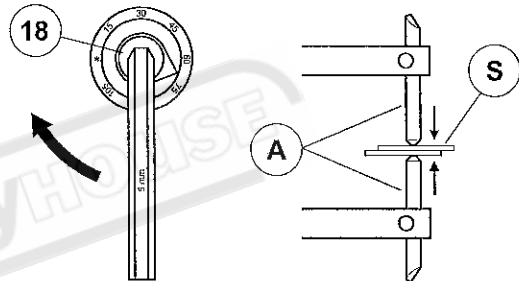

- 6) Turn screw (18) clockwise until electrodes (A) slightly tighten sheets (S).

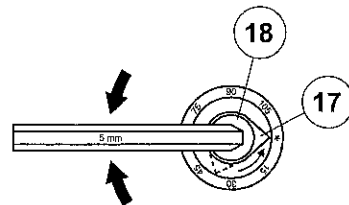

- 7) Keep still screw (18), and move index (17) to zero.

After setting the zero value, it is possible to directly adjust the required electrodes force value by turning clockwise screw (18) with arms (C) open.

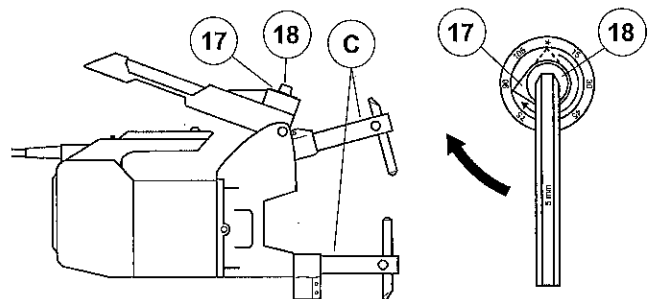

The value should be set according to the thickness of sheets to be welded; it may be selected on the basis of personal experience and the welding tables (see tab. 2).

The values in the force indicator scale refer to arms with a length of L=125 mm. When using other arms either consult table 1 or multiply the set force by the value in the following table to deduce the force value obtained:

Arms length	125	150	250	350	500
Multiply by	1	0.88	0.57	0.42	0.31

Until there is no change greater than 1mm in the thicknesses to be welded, or wear or electrodes (A) displacement, the setting to zero is valid. To change the force, it is enough to adjust, by means of screw (18), the index (17) to the required value.

Welding parameters adjustment

It is possible to adjust the welding time by the knob 56. Table 2 shows the times and setting for various types of welding. The timer has a compensation circuit which calculates the actual welding time needed even when paint, rust or dirt obstruct the passage of welding current, thus the timer only ends the cycle when a perfect complete weld has been obtained.

ITEMS 7902-7903 ONLY:

Welding current can be adjusted from 40% to 100% by means of knob 47. We recommend to always use the highest value except for: very thin thickness, rods with reduced \varnothing (1-3 mm), stainless steel sheets.

Another advantage offered by current adjustment is the possibility of reducing the power absorption when this is too high for the mains on which the welder is used (of course, you have to increase the welding time and check the welds quality).

All versions P of these welders are equipped with pulse function, which is selected by means of selector P. The data in table 2 refers to the "timer" position. The "pulse" position requires longer welding times.

WELDING EXAMPLES

Mild steel sheet mm 0.8 + 0.8 to be welded with 125 mm arms, spot welder item 7900. Table 2 suggests:

- Electrodes tip diameter 4 mm.
- Welding time 9 cycles (knob 56).
- Force on electrodes 75 daN (adjust as previously described).
- Max. working rating 6 spots per minute (table 4).

Mild steel sheet mm 1 + 1 to be welded with 250 mm arms with spot welder item 7902. Table 2 suggests:

- Electrodes tip diameter 4.5 mm
- Welding time 25 cycles (knob 56)
- Current 4/4 (adjust with knob 47)
- Force on electrodes 70 daN (set indicator 17 on 120daN to balance the arms increased length).
- Max. working rating 5 spots per minute (table 4).

SAFETY RULES

For a safe welder use, the installation must be carried out by qualified personnel only; the welder maintenance must be carefully carried out by following all the safety instructions stated in the "MAINTENANCE" paragraph. In particular, notice that the electrodes maintenance must be carried out with the welder switched off. The welder must be used in a place fulfilling the following features:

- In an inner place. The welder has not been designed for being used outdoors.
- Room temperature should be between 0 and 40 °C (If water is removed, storage is allowed down to 20°C below 0); 1000 m. maximum altitudes.
- In a well ventilated area, free from dust, steam, and acid exhalation.

- The work place must be free from inflammable materials because the working process can produce spatter of molten metal.

If the welder is used to carry out welding processes which can cause fumes, a proper aspirator must be installed.

In case of water entering the welder, immediately stop the electrical supply.



Notice that these types of machines generate strong magnetic fields attracting metals (metal prosthesis included) and damaging watches, magnetic cards and magnetic data storage media. Since these magnetic fields can affect pace-makers, metal prosthesis, hearing aids and all other electrical medical devices, the wearers must consult their doctor before approaching to the welding area.



The welded pieces may reach high temperatures. Even some parts of the machine (electrodes, arms and parts connected to the former ones) may excessively heat up if the cooling water is not enough or if the machine is used for a too high rating. Analyse the working conditions and use, if necessary, suitable individual protection devices (gloves, aprons and other clothes).

Personnel must wear both safety glasses and gloves. Avoid wearing rings, metal watches and clothes with either metal accessories or components. When operating heavy working, high thickness and pieces with a difficult coupling, wear safety shoes and aprons, and use protection screens to protect the operator from possible spatter of molten materials.

The safety shoes must be worn each time the pieces, because of their shape or weight, bear risks requiring them.

Keep the area surrounding the welder free from inflammable materials as the work may produce projections of melted metal particles. It is forbidden to use the machine in explosive atmosphere environments or involving fire risks.

Never carry the welder by its cable or yank it to take it off from the socket. Keep the cable away from heat, oil and sharp edges. If, while working, the cable is damaged, unplug the machine from the mains. Do not use the machine if the cable is damaged.

In case of fire do not use water but proper fire extinguishers.

In addition to the information stated in this chapter, always operate in accordance with all the relevant laws in force.

MAINTENANCE

The maintenance operations must be carried out by specialised personnel only, trained to accomplish them under safety conditions. When possible, the welder must be disconnected from electrical supply.

GENERAL MAINTENANCE

GENERAL WARNINGS

- Always check that the screws of electrodes, electrode-holders, arms, and arm-holders (10), as well as the rigid (64-75) and flexible (23) connection are well tightened.
- Remove oxide traces on the secondary circuit with fine sand paper.
- Periodically oil axes 16-16-24-68.
- Keep the spot gun free from dust and metal particles attracted by the magnetic field formed by the welder when in use.
- Neither washing the welding unit with jets of water which could enter it, nor use strong solvents, thinners, nor benzine that could damage either painting or the machine plastic components.

ELECTRODES

- When operating, the electrodes must be kept clean and their diameter must be kept suitable for the work to be carried out. Excessively worn electrodes must be replaced.
- With water cooled arms, do not use sealing products to remove water leakage on the electrode taper. To facilitate electrode removal and to prevent from both taper seizure and leakage, use high conductivity grease similar to the standard one.

COOLING CIRCUIT (ON ITEM 7903 ONLY)

- Check that cooling water circulates freely and in the required quantity and that the input temperature is within 10 and 30°C.
- Check the status of both water hoses and corresponding connections.
- If the welder is to be stored during the winter in a cold environment, first carefully drain the cooling circuit to prevent damage caused by frozen water.

ELECTRICAL CIRCUIT

- Periodically check ground efficiency.
- Periodically check the mains cable.

EXTRAORDINARY MAINTENANCE

If the welder overheats, check that the duty cycle is not too high (table 4), the electrode tip diameter is correct (table 2); on water cooled models check that water flow is adequate.

Item 7903 is equipped with a thermostatic protection which stops the welder in case of insufficient water. The thermostat does not protect the transformer against work overloading.

If performances are lower than expected check:

- that, when welding, line voltage drop is lower than 15%;

- that the supply cables section is adequate;
- that the electrodes diameter is appropriate for the work to be carried out;
- on item 7903 that the cooling water flows in the required quantity;
- that the set welding force is adequate for the work in process.

SPARE PARTS

Look at the exploded views and at the spare parts list at the end of this instruction manual to identify the code of the required parts. The first number of the code has the following meaning:

- 1.... standard components widely available from industrial suppliers (e.g. screws, washers, nuts, etc.).
- 2.... commercial components which, providing that the same quality parameters are adopted, can be purchased anywhere (hoses, switches etc.).
- 3.... components manufactured by TECNA
- 4.... components manufactured by TECNA
- 5.... electronic circuits and assemblies manufactured by TECNA.
- 7.... assemblies composed of parts belonging to any or all of the above codes but which for the sake of simplicity are available ready-assembled.

All spare parts, including standard or commercial ones, are available from TECNA. When ordering please always state code number, and quantity of the spare parts, voltage and frequency, the serial number, and year of manufacture of the welder. The code number followed by an asterisk warns that the part changes depending on the mains voltage.

REMEDIES FOR WELDS IMPERFECTIONS.

This chapter has been introduced in order to facilitate the troubleshooting of the most common imperfections caused by incorrect adjustment. Notice that each one can be caused by different causes as there are many parameters affecting the welding process. The following table specifically refers to low carbon steel spot welding, but, with the due consideration, it can also be useful for other applications.

FAULT	POSSIBLE CAUSE	POSSIBLE REMEDY
Weak welding	Low welding current.	Increase it.
	Low welding time.	Increase it.
	Too high electrodes force.	Reduce pressure.
	Lacking electrodes maintenance or too high electrodes diameter.	Clean and line up the electrodes, restore their dimensions.
	Faulty pieces contact.	Increase the electrodes force.
Spatter of molten material	Paint or dirt among pieces.	Clean the pieces.
	Inadequate electrodes cooling.	Check the cooling circuit.
	Faulty pieces contact or pieces and electrodes faulty contact.	Increase the electrodes force by increasing pressure.
	Too high welding current.	Reduce it.
	Too high welding time.	Reduce it.
	Too small electrodes diameter.	Adjust diameter to the value shown on the table.
	Inadequate welding force.	Increase pressure.
Electrodes faulty clamping of the pieces.	Check stroke.	
Burned welds or welds showing either craters or fissures.	Too high welding current.	Reduce it.
	Inadequate welding force.	Increase welding pressure.
	Oxidised pieces to weld.	Clean them by means of emery paper.
	Faulty pieces contact or pieces and electrodes faulty contact.	Increase electrodes force.
	Faulty pieces lining up.	Correct it.
Work pieces stuck on the electrode	Electrodes tips deformations.	Restore them to the correct size.
	Too high welding current.	Reduce it.
	Inadequate electrodes diameter.	Restore it to the correct dimensions.
Electrodes and connections reduced life (position 21).	Inadequate welding force.	Increase the welding pressure.
	Under-sized electrode in comparison with the work to be done	Check both size and contact diameter.
Secondary connection reduced life and oxidation.	Heating caused by an inadequate clamping of the flexible connection.	Carefully tighten the clamping screws.
	Too high heating caused by a too high welding rate.	Reduce it.

**MESSA A PUNTO DELLA PUNTATRICE - ADJUSTING THE SPOT WELDER - REGLAGE DE LA SOUDEUSE PAR POINTS
EINSTELLUNG DER PUNKTSCHWEIßZANGE - PUESTA A PUNTO DE LA PINZA**

Fig. 1

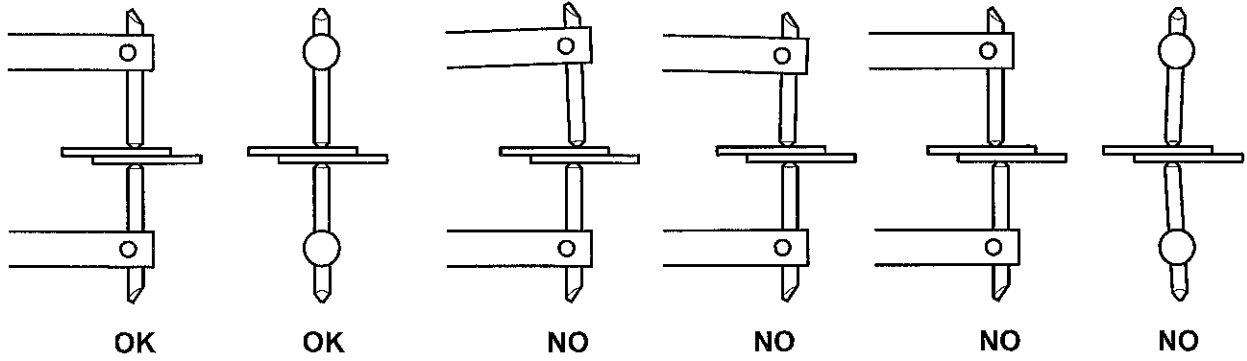

Fig. 2

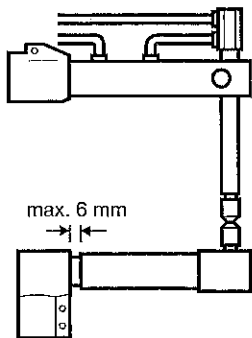

Fig. 3

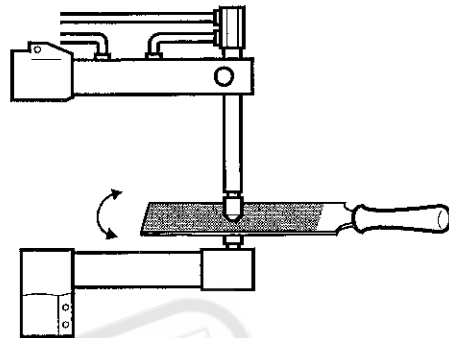

Fig. 4

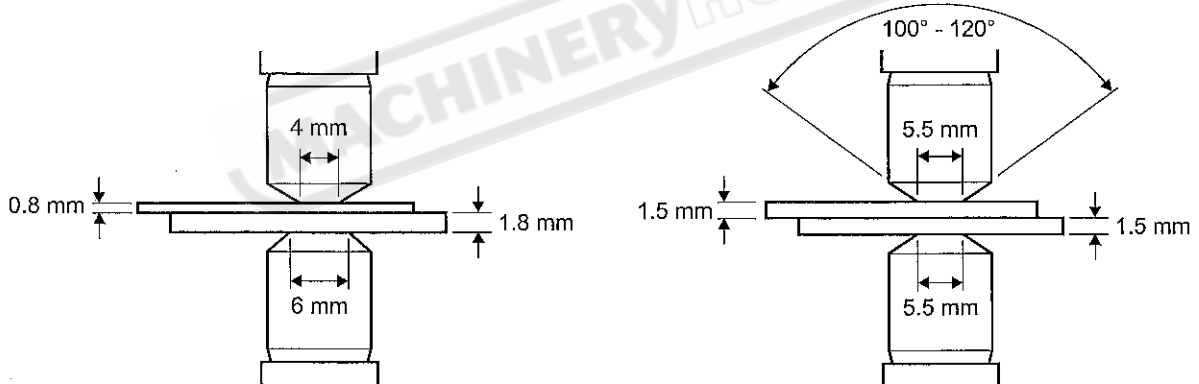
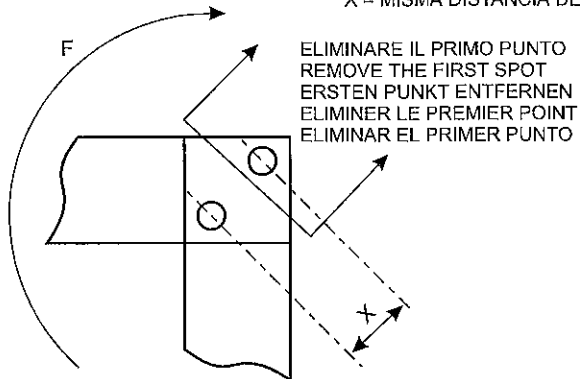
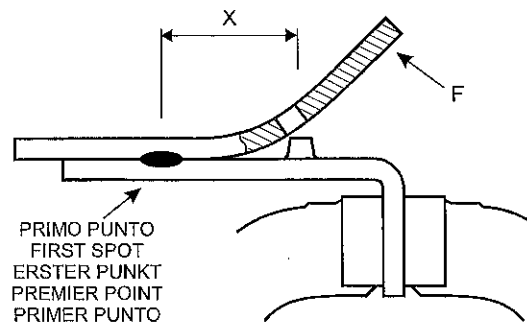

Fig. 5

X = STESSA DISTANZA DEI PUNTI IN PRODUZIONE - X = SAME DISTANCE OF SPOTS IN PRODUCTION
X = GLEICHE ENTFERNUNG DER PUNKTE BEI PRODUKTION - X = MEME DISTANCE QUE POUR LE POINTS EN PRODUCTION
X = MISMA DISTANCIA DE PUNTOS EN PRODUCCIÓN



TEST DI TORSIONE - TWIST TEST
VERDREHUNG - TORSION - TORSIÓN



TEST DI TRAZIONE - PULLING TEST
SPANNUNG - TRACTION - TRACCIÓN

TABELLE UTILI PER LE PRESTAZIONI E REGOLAZIONI DELLA PUNTATRICE - TABLES USEFUL FOR PERFORMANCE AND ADJUSTMENTS OF THE SPOT GUN - TABLEAUX UTILES POUR LES PRESTATIONS ET LES REGLAGES DE LA PINCE A SOUDER - TABELLEN FUR LEISTUNG UND EINSTELLUNG DER PUNKTSCHWEIßZANGE - TABLAS UTILES PARA LAS PRESTACIONES DE LA PINZA

Tab. 1 Forza agli elettrodi per le differenti lunghezze dei bracci. - Force on electrodes for different arms lengths. - Force aux électrodes pour des longueurs de bras différentes. - Elektrodendruck bei verschiedenen Armlängen. - Fuerza entre electrodos para diferentes longitudes de brazos.

con bracci - with arms - avec bras - mit Armen - con brazos				
125 mm	150 mm	250 mm	350 mm	500 mm
120 daN	105 daN	68 daN	50 daN	38 daN
105 daN	92 daN	60 daN	44 daN	32 daN
90 daN	80 daN	51 daN	38 daN	28 daN
75 daN	66 daN	42 daN	31 daN	23 daN
60 daN	52 daN	34 daN	25 daN	-
45 daN	40 daN	26 daN	-	-
30 daN	26 daN	-	-	-

Tab. 2 Esempi di saldatura - Welding examples - Exemples de soudage - Schweißbeispiele - Ejemplos de soldadura

				Forza Force Effort Kraft Fuerza		Bracci L= (mm) Arms L= (mm) Bras L= (mm) Arme L= (mm) Brazos L= (mm)			Tempo di saldatura Welding time Temps de soudage Schweißzeiten Tiempo soldadura			Regolazione corrente Current adjustment Réglage du courant Stromeinstellung Reglaje de corriente		Val. indicati su scala E Values stated on scale E Valeurs indiquées sur échelle E Werte angegeben auf Skala E Valores indicados en la escala E		
mm	mm	mm	mm	7900	7903	7900	7902	7903	7900	7902	7903	7902	7903	7900	7902	7903
				7902	daN											
3.5	0.6	0.6	3.5	60	60	125	125	150	3 ~	2 ~	4 ~	1/4	1/4	60	60	70
4	0.8	0.8	4	75	75	125	125	150	9 ~	7 ~	6 ~	1/2	1/2	75	75	85
4.5	1	1	4.5	90	92	125	125	150	14 ~	14 ~	14 ~	3/4	3/4	90	90	105
5.5	1.5	1.5	5.5	100	105	125	125	150	30 ~	25 ~	20 ~	4/4	4/4	100	100	120
6	1.8	1.8	6	115	105	125	125	150	55 ~	45 ~	40 ~	4/4	4/4	115	115	120
4	0.8	0.8	4	60	60	250	250	250	12 ~	12 ~	8 ~	3/4	3/4	105	105	105
4.5	1	1	4.5	68	68	250	250	250	30 ~	25 ~	12 ~	4/4	4/4	120	120	120
5.5	1.5	1.5	5.5	68	68	250	250	250	50 ~	40 ~	50 ~	4/4	4/4	120	120	120
4.5	1	1	4.5	50	50	350	350	350	35 ~	25 ~	25 ~	4/4	4/4	120	120	120
4.5	1	1	4.5	38	38	500	500	500	55 ~	35 ~	35 ~	4/4	4/4	120	120	120
12	Ø 5	Ø 5	12	75	75	125	125	150	23 ~	18 ~	12 ~	4/4	4/4	75	75	85
12	Ø 6	Ø 6	12	95	97	125	125	150	30 ~	25 ~	30 ~	4/4	4/4	95	95	110

Tab. 3 Capacità massima di saldatura su acciaio dolce - Maximum welding capacity on mild steel - Capacité de soudage maxi. sur acier doux - Max. Schweißleistung bei Stahlblech - Capacidad máxima de soldadura en acero dulce

Lunghezza bracci Arms length Longueur bras Ausladung Arme Longitud brazos	Forza max. agli elettrodi Max. force on electrodes Effort max. aux électrodes Max. Elektrodenkraft Fuerza máxima entre electrodos	Apertura elettrodi Electrodes opening Ouverture électrodes Öffnung der Elektroden Abertura electrodos	Spessore massimo Max. thickness Épaisseur maximum Max. Materialstärke Espesor máximo		
			7900	7902	7903
mm	daN	mm	mm	mm	mm
125	120	55	2 + 2	2.5 + 2.5	2 + 2
150	100	70	1.8 + 1.8	2.2 + 2.2	2 + 2
250	70	105	1.8 + 1.8	2 + 2	1.8 + 1.8
350	50	135	1.5 + 1.5	1.8 + 1.8	1.5 + 1.5
500	38	185	1.2 + 1.2	1.6 + 1.6	1.2 + 1.2

Tab. 4 Cadenza massima di lavoro - Maximum spots per minute - Cadence maxi. de travail - Max. Arbeitstakt - Cadencia máxima de trabajo

Spessore mm Thickness mm Épaisseur mm Materialstärke mm Espesor mm	Cadenze punti/minuto Spots/min Cadence points/min. Schweißpunkte pro min Cadencia, puntos/min			Ø del punto mm Spots Ø mm Ø points mm Ø Schweißpunkte mm Ø del punto mm
	7900	7902	7903	
0.6 + 0.6	9	10	40	3.5
0.8 + 0.8	6	6	30	4
1 + 1	5	5	25	4.5
1.2 + 1.2	4	4	16	5
1.5 + 1.5	2	2	10	5.5
1.8 + 1.8	2	2	8	6
Ø 5 + 5	8	8	40	-
Ø 6 + 6	3	4	15	-

Tab. 5 Dimensionamento della linea e dei fusibili - Size of mains cable and fuses required - Section des câbles de l'installation et fusibles - Querschnitt der Leitung und Schmelzsicherungen - Sección de la línea y fusibles

		Tensione di alimentazione - Power supply Tension d'alimentation - Anschlußspannung Tensión de alimentación	
		220-230-240 V	380-400-415 V
Distanza contatore/puntatrice Distance electric meter/spot welder Distance compteur/soudeuse par points Abstand Zähler/Punktschweißzange Distancia contador/máquina	15 m - 45 feet 25m - 30 yards 60 m - 66 yards	4 mm ² 6 mm ² 10 mm ²	2.5 mm ² 4 mm ² 6 mm ²
Spina - Plug - Fiche - Stecker - Enchufe		7900-7902 16 A 7903 25 A	16 A
Fusibili - Fuses - Fusibles - Sicherungen - Fusibles		25 A	16 A
Fusibili ritardati - Delayed fuses - Fusibles à grande inertie Verzögerte Sicherungen - Fusibles retardados		7900-7902 16 A 7903 20 A	16 A
Interruttore magnetotermico - Circuit breaker - Disjoncteur magnétothermique - FI-Schutzschalter - Interruptor magneto- térmico		7900-7902 16 A 7903 20 A	16 A

Fig. 6 Esempi di installazione elettrica - Example of electrical installation - Exemples d'installation électrique - Beispiele elektrische Installation - Ejemplos de instalación eléctrica

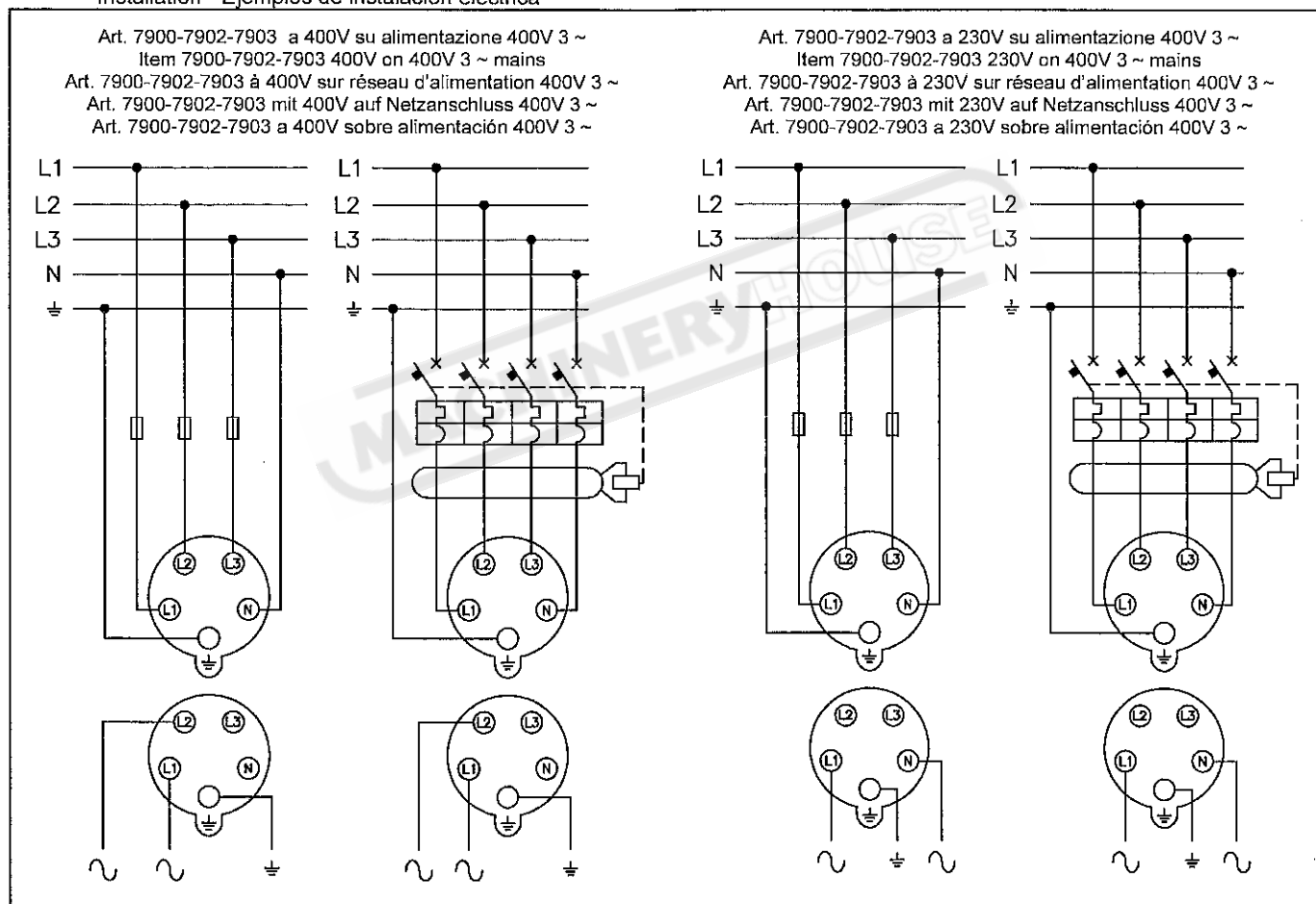

Fig. 7 Art./Item 7900 - Schema elettrico - Wiring diagram - Schéma électrique - Schaltplan - Esquema eléctrico

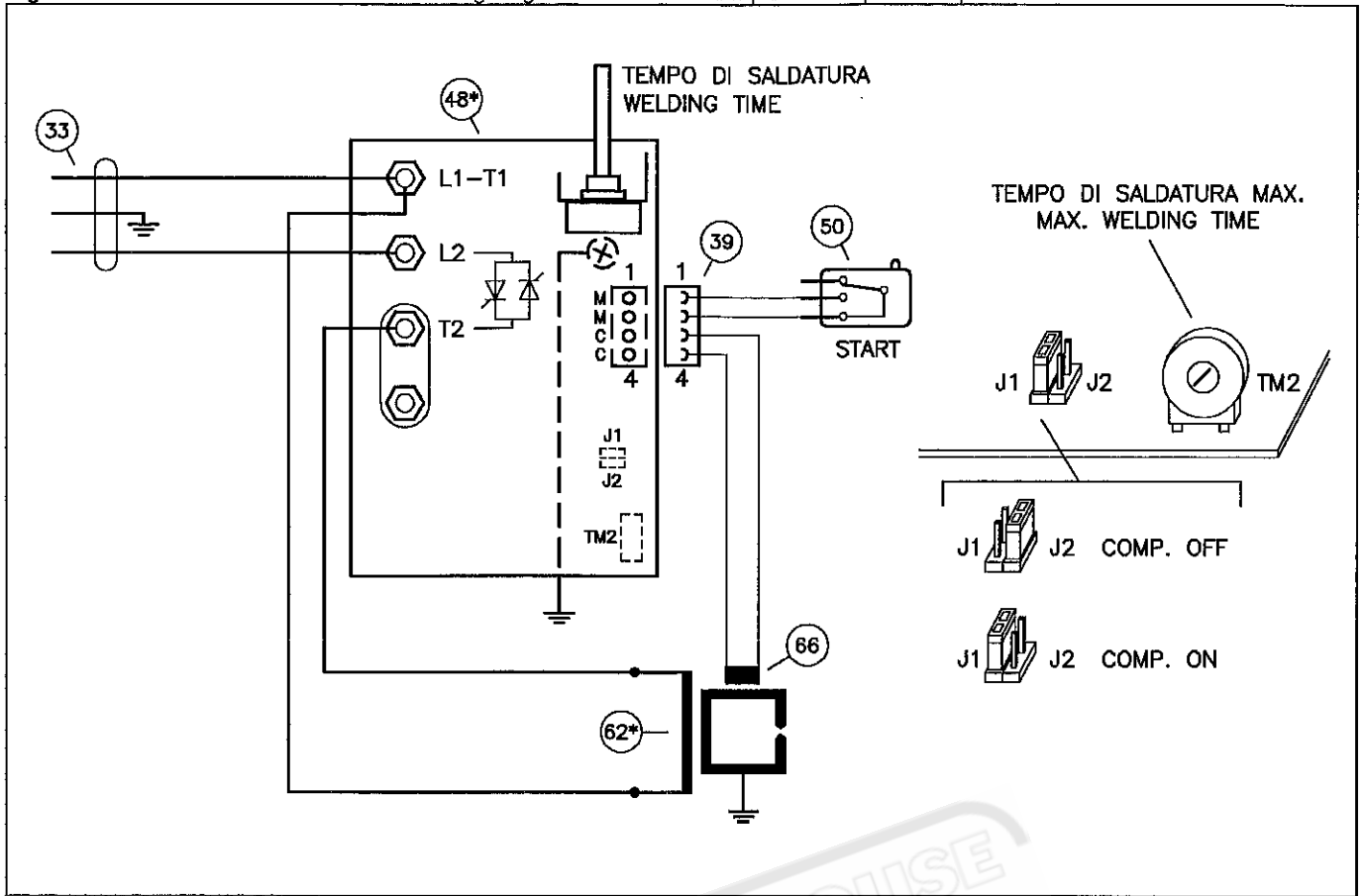

Fig. 8 Art./Item 7902 - Schema elettrico - Wiring diagram - Schéma électrique - Schaltplan - Esquema eléctrico

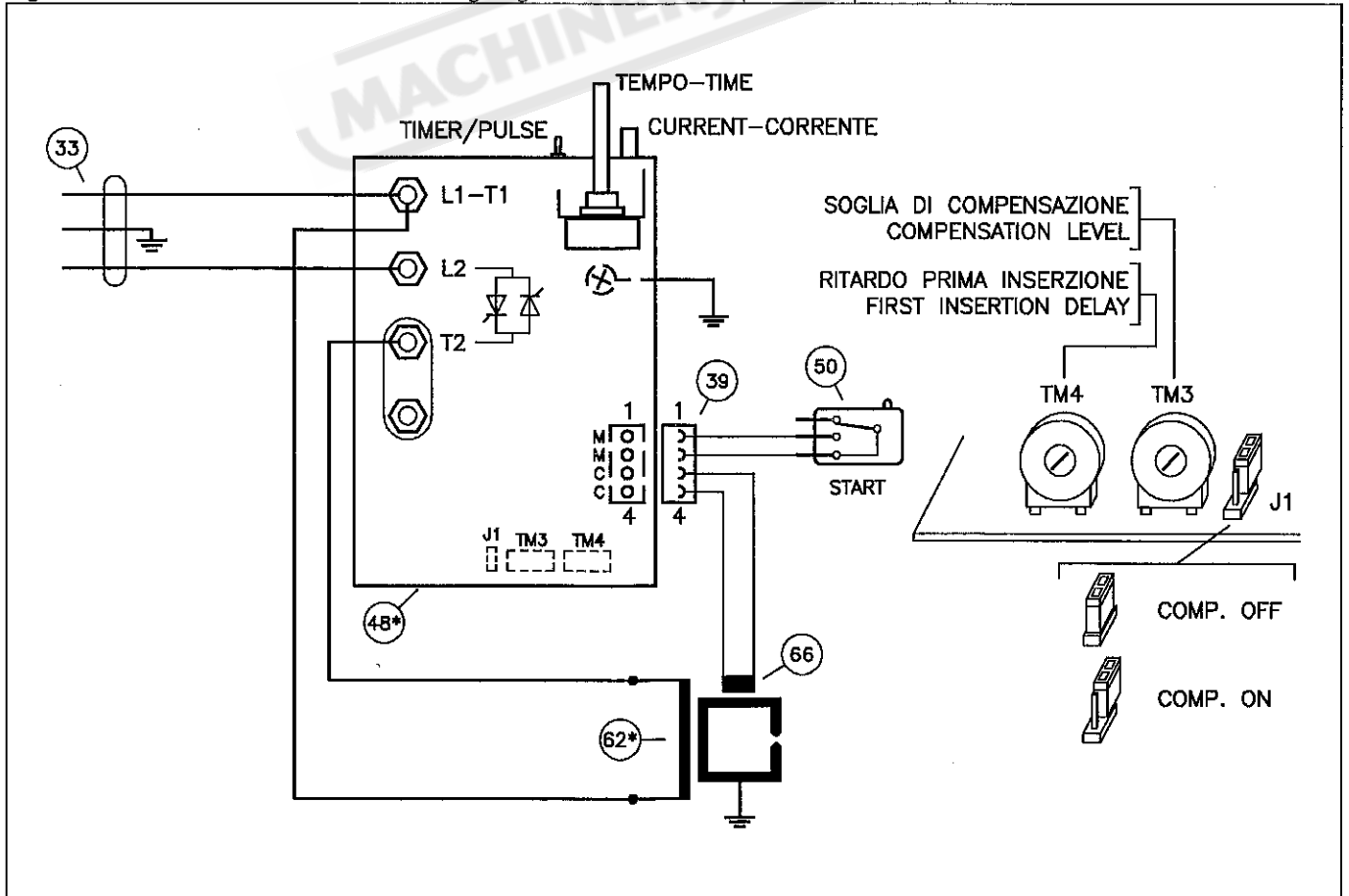
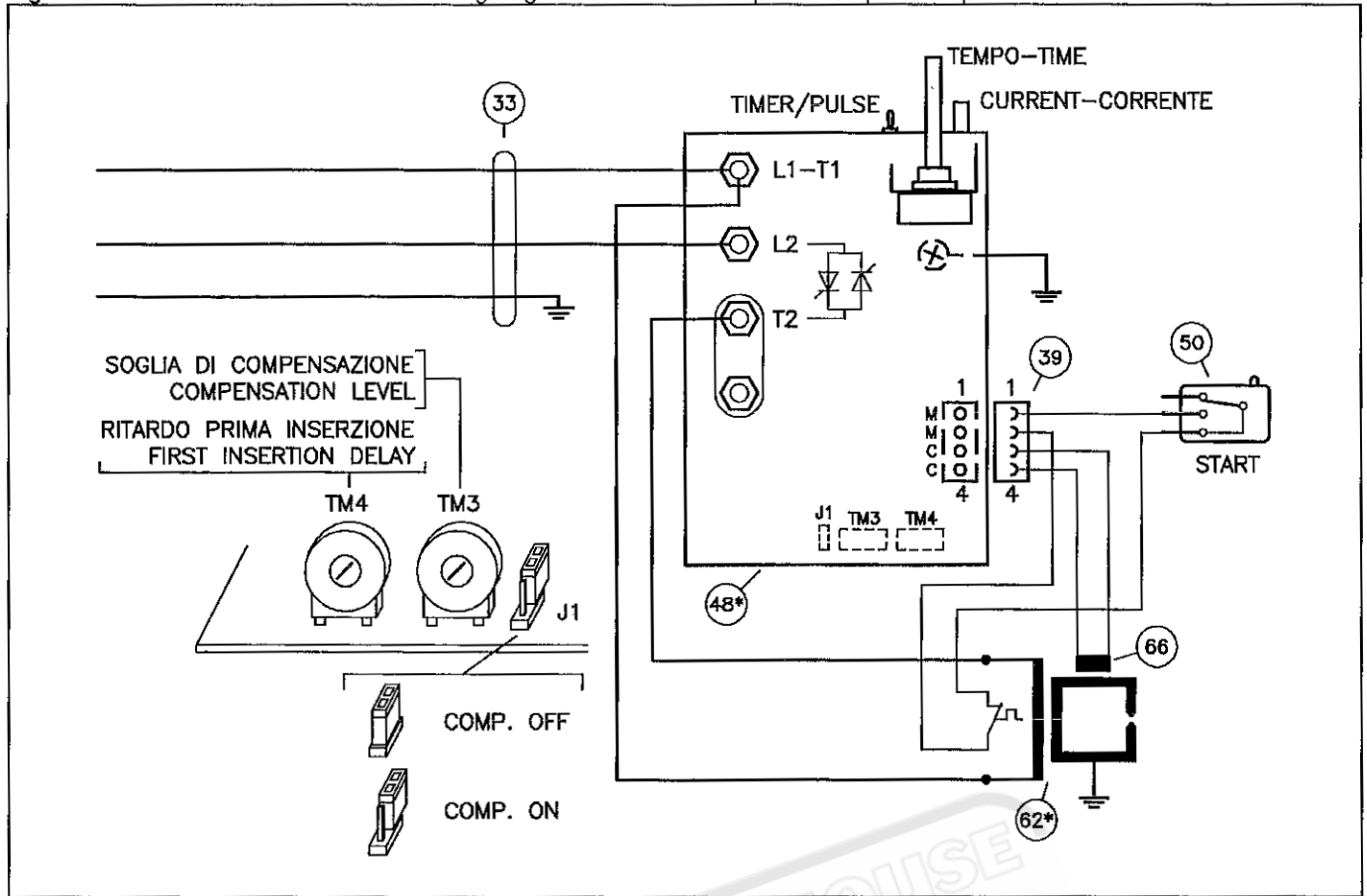

Fig. 9 Art./Item 7903 - Schema elettrico - Wiring diagram - Schéma électrique - Schaltplan - Esquema eléctrico



TECNA S.p.A.

Via Grieco 25/27
40024 Castel S. Pietro Terme (BO)
ITALY

DICHIARAZIONE DEL COSTRUTTORE
MANUFACTURER DECLARATION
DECLARATION DU CONSTRUCTEUR
HERSTELLER-ERKLÄRUNG
DECLARACION DEL FABRICANTE

Dichiaro sotto la nostra unica responsabilità che il prodotto
We declare under our sole responsibility for supply/manufacture of the product
Nous déclarons sous notre seule responsabilité que le produit
Wir erklären unter einziger Verantwortung, dass das Produkt
Certificamos bajo nuestra sola responsabilidad que el producto

SALDATRICE A RESISTENZA
RESISTANCE WELDER
SOUDEUSE PAR RESISTANCE
WIDERSTANDSSCHWEISS-MASCHINE
MAQUINAS DE SOLDADURA POR RESISTENCIA

Modello Model Modèle Type Modelo

7900 - 7902 - 7902P
7903 - 7903P

Numero di serie
Serial number
Numéro de série
Serien-Nummer
Número de serie

DA 15000 A 19999
FROM 15000 TO 19999
DE 15000 A 19999
VON 15000 BIS 19999
DE 15000 A 19999

È conforme alle prescrizioni delle norme Europee
Is in conformity with the provisions of the European standards
Est conforme aux prescriptions de la norme européenne
mit der europäischen Norm konform ist
Es conforme a las prescripciones de la norma europea

EN50063
EN50240

È conforme alle prescrizioni delle direttive CEE
Is in conformity with the provisions of the EEC Directives
Est conforme aux prescriptions des Directives CEE
mit EG-Richtlinien konform ist
Es conforme a las prescripciones y directivas de la CEE

73/23/EEC
89/336/EEC

l'amm.re unico
Ezio Amadori

CASTEL S. PIETRO T. 26 / 02 / 2007

Fig. 10 Art./Item 7900-7902 Disegno esploso - Exploded view - Vue éclatée - Ersatzteilzeichnung - Croquis

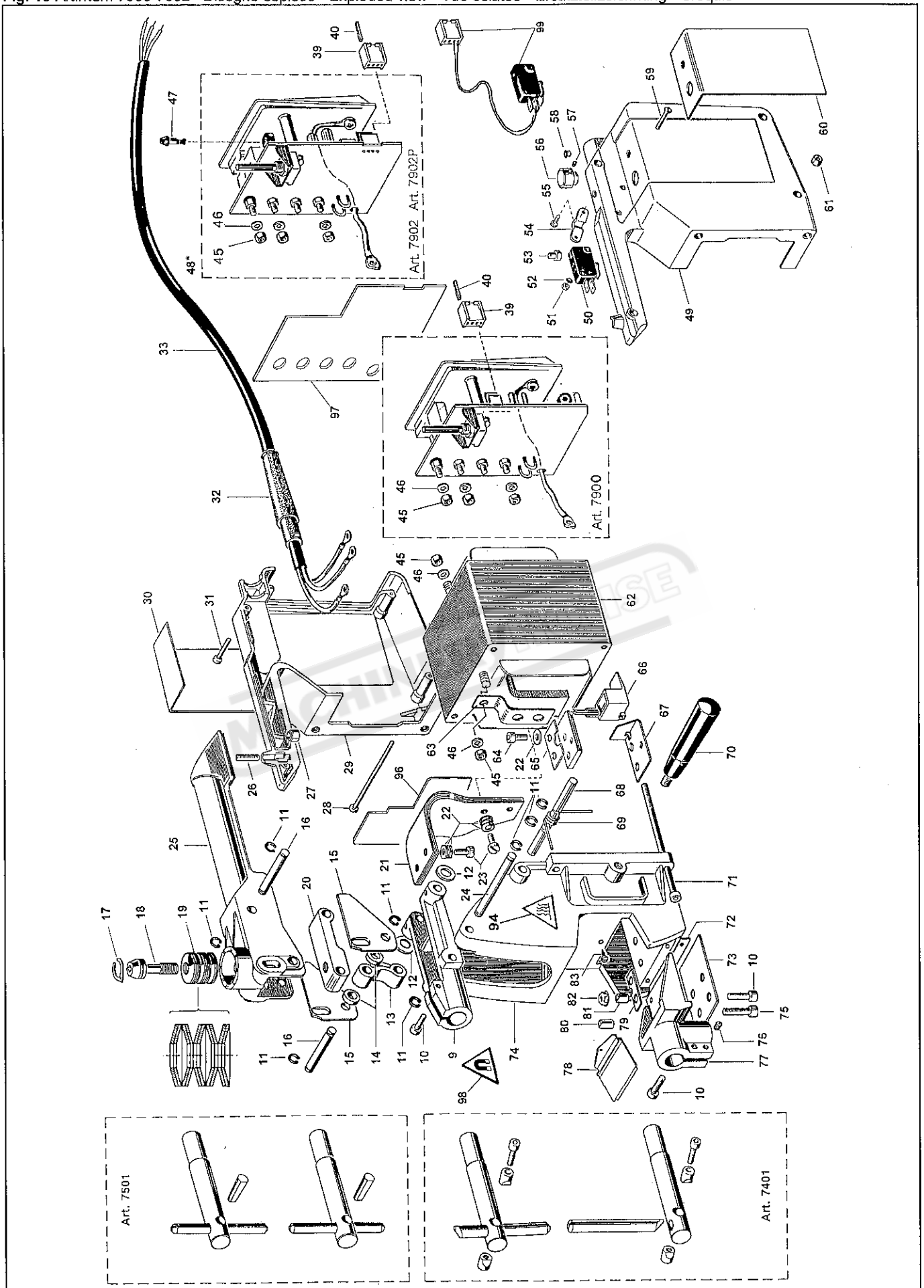
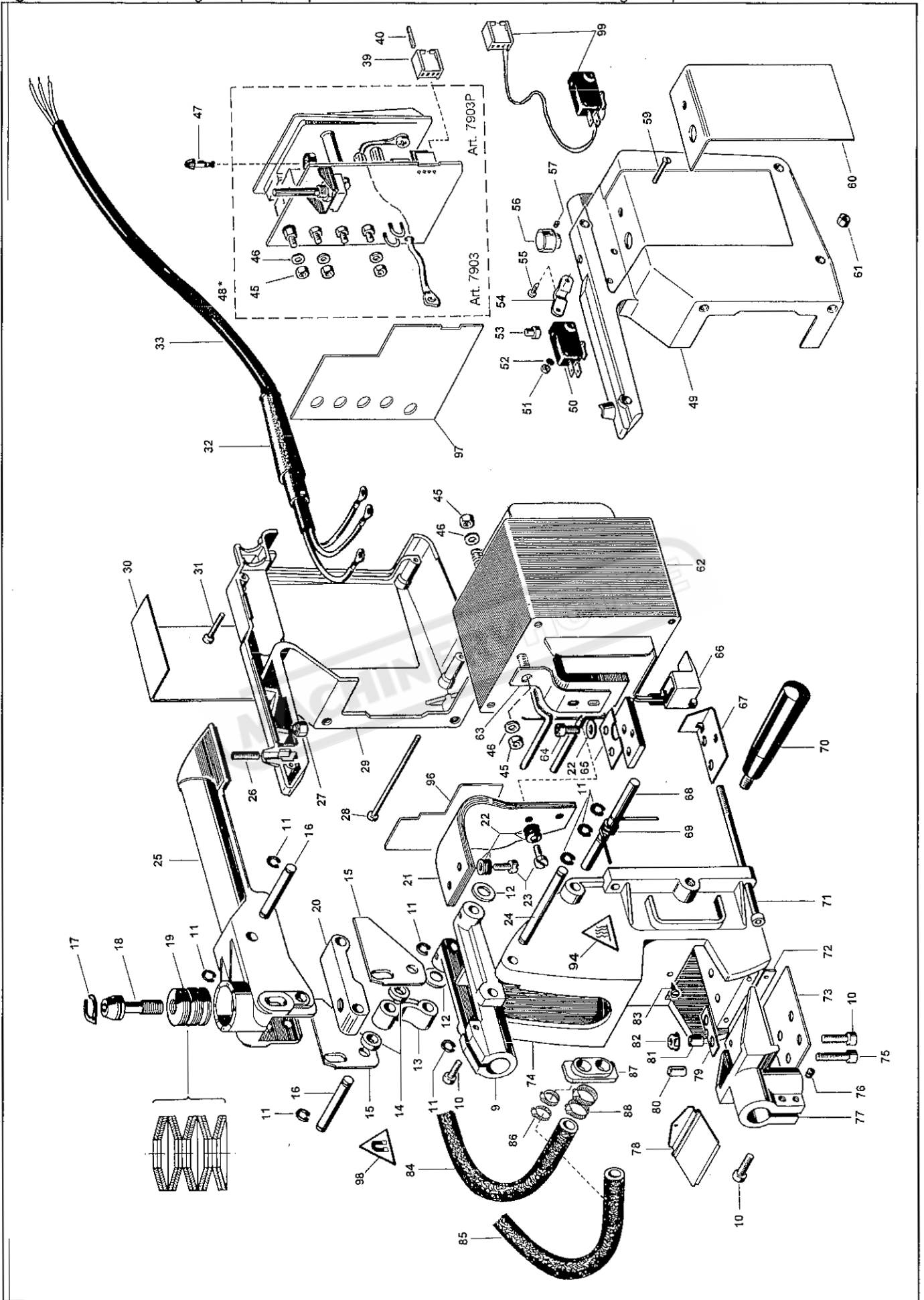

Fig. 11 Art./Item 7903 Disegno esploso - Exploded view - Vue éclatée - Ersatzteilzeichnung - Croquis



ART. 7900-7902-7903 DISTINTA RICAMBI - SPARE PARTS LIST - LISTE DE PIÉCES DÉTACHÉES - ERSATZTEIL-LISTE - LISTA DE PIEZAS DE RICAMBIO (26/02/2007)

SOLO ONLY Art./Item	POS.	QT.	CODICE CODE	DENOMIMAZIONE	DENOMINATION	DENOMINATION	BEZEICHNUNG	DENOMINACION
	9	1	38021	Porta braccio	Arm-holder	Porte-bras	Armshalter	Portabrazo
	10	4	10023	Viti	Screws	Vis	Schraube	Tornillos
	11	10	10054	Anelli di fermo	Circlips	Bagues d'arrêt	Sicherungsringe	Anillos elasticos
	12	2	30097	Isolanti	Insulators	Isolants	Isolierungen	Aislante
	13	1	30979	Biella	Rod	Bielle	Verbindungsstück	Biela
	14	2	31431	Distanziali	Spacers	Entretoises	Distanzstücke	Separadores
	15	2	31427	Supporti	Support	Support	Halter	Soporte
	16	3	30071	Asse	Axe	Axe	Achse	Eje
	17	1	31426	Indice	Index	Indicateur	Anzeige	Indice
	18	1	31424	Registro	Adjuster	Réglage	Register	Reglaje
	19	10	20739	Molle	Springs	Ressorts	Federn	Resortes
	20	1	31563	Biella	Rod	Bielle	Pleulstange	Biela
	21	1	38975	Connessione	Connection	Connexion	Stromband	Conexion
	22	9	10008	Rondelle	Washers	Rondelles	Scheibe	Arandelas
	23	4	10660	Viti	Screws	Vis	Schraube	Tornillos
	24	1	30146	Asse	Axe	Axe	Achse	Eje
	25	1	44353	Leva	Lever	Levier	Hebel	Leva
	26	1	10587	Vite	Screw	Vis	Schraube	Tornillo
	27	1	10062	Dado	Nut	Ecrou	Mutter	Tuerca
	28	2	10002	Viti	Screws	Vis	Schrauben	Tornillos
	29	1	49080	Calotta destra	Right cover	Carter droite	Gehäuse rechts	Carcasa derecha
	30	1	32710	Targa	Plate	Plaque	Schild	Tarjeta
	31	2	10000	Viti	Screws	Vis	Schrauben	Tornillos
	32	1	30040	Passacavo	Cable guide	Guide-câble	Knickschutz	Pasabornes
	33	1	20060	Cavo alimentaz.4 m	Mains cable 4 m	Câble réseau 4 m	Anschlusskabel 4m	Cable alimentation 4m
7900	34	1	50155*	Timer SCR 200÷415V 50/60Hz	SCR timer 200÷415V 50/60Hz	Temporisateur à SCR 200÷415V 50/60Hz	Zeitgeber SCR 200÷415V 50/60Hz	Temporizador SCR 200÷415V 50/60Hz
	39	1	20451	Connettore	Connector	Connecteur	Anschluss	Conector
	40	4	20452	Contatti	Contacts	Contacts	Kontakte	Contactos
	45	3	10426	Dadi	Nuts	Ecrous	Muttern	Tuercas
	46	3	10098	Rondelle	Washers	Rondelles	Scheiben	Arandelas
7902X 7903X	47	1	31267	Pomello	Knob	Molette	Schaltknopf	Manguito
7902 7903	48	1	50142*	Timer SCR 380÷415V 50/60Hz	SCR timer 380÷415V 50/60Hz	Temporisateur à SCR 380÷415V 50/60Hz	Zeitgeber SCR 380÷415V 50/60Hz	Temporizador SCR 380÷415V 50/60Hz
7902 7903	48	1	50179*	Timer SCR 200÷240V 50/60Hz	SCR timer 200÷240V 50/60Hz	Temporisateur à SCR 200÷240V 50/60Hz	Zeitgeber SCR 200÷240V 50/60Hz	Temporizador SCR 200÷240V 50/60Hz
7902P 7903P	48	1	50143*	Timer SCR 380÷415V 50/60Hz	SCR timer 380÷415V 50/60Hz	Temporisateur à SCR 380÷415V 50/60Hz	Zeitgeber SCR 380÷415V 50/60Hz	Temporizador SCR 380÷415V 50/60Hz
7902P 7903P	48	1	50192*	Timer SCR 200÷240V 50/60Hz	SCR timer 200÷240V 50/60Hz	Temporisateur à SCR 200÷240V 50/60Hz	Zeitgeber SCR 200÷240V 50/60Hz	Temporizador SCR 200÷240V 50/60Hz
7902 7903	49	1	49081	Calotta sinistra	Left cover	Carter gauche	Gehäuse links	Carcasa izquierda
7902P 7903P	49	1	49192	Calotta sinistra	Left cover	Carter gauche	Gehäuse links	Carcasa izquierda
	50	1	20000	Microinterruttore	Microswitch	Microinterrupteur	Mikroschalter	Microinterruptor
	51	2	10046	Dadi	Nuts	Ecrous	Mutter	Tuercas
	52	2	10148	Rondelle	Washers	Rondelles	Scheibe	Arandelas
	53	1	31398	Pulsante	Push-button	Poussoir	Drucktaste	Pulsador
	54	1	31438	Farmacavo	Cable guide	Guide-câble	Kabelklemme	Pasabornes
	55	2	10535	Viti	Screws	Vis	Schraube	Tornillos
	56	1	31264	Manopola	Knob	Molette	Drehknopf	Mango
	57	1	10463	Vite	Screw	Vis	Schraube	Tornillo
7900	58	1	20716	Tappo	Cap	Bouchon	Verschluss	Tapón
	59	2	10284	Viti	Screws	Vis	Schrauben	Tornillos
7900	60	1	32707	Targa	Plate	Plaque	Schild	Tarjeta
7902	60	1	32708	Targa	Plate	Plaque	Schild	Tarjeta
7902P	60	1	32708	Targa	Plate	Plaque	Schild	Tarjeta
7903	60	1	32709	Targa	Plate	Plaque	Schild	Tarjeta
7903P	60	1	32709	Targa	Plate	Plaque	Schild	Tarjeta
	61	4	10003	Dadi	Nuts	Ecrous	Muttern	Tuercas
7900	62	1	44794*	Trasformatore 2 kVA	Transformer 2 kVA	Transformateur 2 kVA	Transformator 2 kVA	Transformador 2 kVA
7902 7902P	62	1	44809*	Trasformatore 2,5 kVA	Transformer 2.5kVA	Transformateur 2.5kVA	Transformator 2.5 kVA	Transformador 2.5 kVA
7903 7903P	62	1	44796*	Trasformatore 6 kVA	Transformer 6 kVA	Transformateur 6 kVA	Transformator 6 kVA	Transformador 6 kVA
	63	2	32700	Connessione	Connection	Connexion	Verbindungsblech	Conexión
	64	1	10059	Vite	Screw	Vis	Schraube	Tornillo
	65	1	30142	Isolante	Insulator	Isolant	Isolierung	Aislante
	66	1	31250	Bobina	Coil	Bobine	Kompensationsspuile	Bobina
	67	1	30090	Fermo	Stop	Arrêt	Befestigung	Tope

	68	1	32426	Asse	Axe	Axe	Achse	Eje
	69	1	31500	Molla	Spring	Ressort	Feder	Muelle
	70	1	20002	Impugnatura	Handle	Poignée	Griff	Empuñadura
	71	4	10060	Viti	Screws	Vis	Schrauben	Tornillos
	72	1	30078	Isolante	Insulator	Isolant	Isolierung	Aislante
	73	1	30079	Isolante	Insulator	Isolant	Isolierung	Aislante
7900 7902X	74	1	44004	Calotta anteriore	Front housing	Carter avant	Vorderes Gehäuse	Carcasa anterior
7903X	74	1	44429	Calotta anteriore	Front housing	Carter avant	Vorderes Gehäuse	Carcasa anterior
	75	2	10007	Viti	Screws	Vis	Schrauben	Tornillos
	76	1	10101	Vite	Screw	Vis	Schrauben	Tornillo
	77	1	38020	Portabraccio	Arm holder	Porte-bras	Armhalter	Portabrazo
	78	1	30070	Protezione	Protection	Protection	Abdeckung	Protección
	79	1	30076	Isolante	Insulator	Isolant	Isolierung	Aislante
	80	2	30074	Isolanti	Insulators	Isolants	Isolierungen	Aislantes
	81	2	30075	Isolanti	Insulators	Isolants	Isolierungen	Aislantes
	82	4	10009	Dadi	Nuts	Ecrous	Muttern	Tuercas
	83	1	10061	Vite	Screw	Vis	Schraube	Tornillo
7903	84	8 m	20082	Tube gomma	Hose	Tuyau	Schlauch	Tube
7903	85	0.3 m	20081	Tube gomma	Hose	Tuyau	Schlauch	Tube
7903	86	2	20080	Fascette	Clamps	Colliers	Schelle	Abrazadera
7903	87	1	30159	Isolante	Insulator	Isolant	Isolierung	Aislante
7903	88	2	20033	Fascette	Clamps	Colliers	Schelle	Abrazadera
	93	1	21638	Targa	Plate	Plaque	Schild	Tarjeta
	94	1	33050	Connessione	Connection	Connexion	Verbindungsblech	Conexión
	95	1	30499	Connessione	Connection	Connexion	Verbindungsblech	Conexión
	96	1	32947	Isolante	Insulator	Isolant	Isolierung	Aislante
	97	1	32436	Isolante	Insulator	Isolant	Isolierung	Aislante
	98	1	33308	Targa	Plate	Plaque	Schild	Tarjeta
	99	1	70570	Microinterruttore+ Connettore+Contatti (50+39+40)	Microswitch+ Connector+Contacts (50+39+40)	Microinterrupteur+ Connecteur+Contacts (50+39+40)	Mikroschalter+ Anschluss+Kontakte (50+39+40)	Microinterruptor+ Conector+Contactos (50+39+40)

* Altre tensioni e frequenze a richiesta / Different voltages and frequencies on request / Voltages et tensions différentes sur demande / Andere Spannungen und Frequenzen auf Anfrage / Otras tensiones y frecuencias bajo demanda.

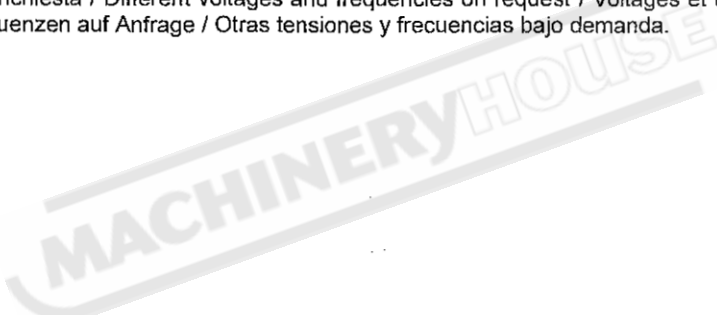

PUNTATRICE PUNKTSCHWEISSZANGE	SPOT WELDER PINZA DE SOLDADURA	PINCE A SOUDER	ART. ITEM	7900
NUMERO DI SERIE SERIEN	SERIAL NUMBER MATRICULA	NUMERO DE SERIE		
MESE / ANNO MONAT / JAHR	MONTH / YEAR MES / AÑO	MOIS / ANNÉE		
VOLT / Hz				230/50
COLLAUDO PRÜFPROTOKOLL	TEST PRUEBA	ESSAI	GUALANDI D.	

ACCESSORI - ACCESSORIES - ACCESSOIRES - ZUBEHÖRE - ACCESORIOS

Elettrodi / Electrodes / Electrodes / Elektroden / Electrodo Ø 12

Bracci / Arms / Bras / Arme / Brazos Ø 22

Art. 7401 L=125 mm
 Art. 7402 L=250 mm
 Art. 7403 L=350 mm
 Art. 7404 L=500 mm
 Art. 7451 Ø 12 ●

Art. 7452 Ø 12 ●

Art. 7406 L=350 mm
 Art. 7407 L=500 mm
 Art. 7453 Ø 12 elettrodo inferiore/
 lower electrode/electrode inférieure/
 untere Elektrode/electrodo inferior
 Art. 7454 Ø 12 elettrodo superiore/
 upper electrode/electrode supérieure/
 obere Elektrode/electrodo superior

Elettrodi / Electrodes / Electrodes / Elektroden / Electrodo Ø 10

Bracci / Arms / Bras / Arme / Brazos Ø 20

Art. 7501 L=125 mm
 Art. 7502 L=250 mm
 Art. 7503 L=350 mm
 Art. 7504 L=500 mm
 Art. 7521 Ø 10 ●

Art. 7507
 Art. 7524 Ø 10 ●

Art. 7509
 Art. 7523 Ø 10 ●

Art. 7510
 Art. 7533 Ø 10 + Ø 12 ●

Art. 7516
 Art. 7523 Ø 10 ●

Art. 7506
 L=250 mm
 Art. 7511
 L=125 mm
 Art. 7523 Ø 10 ●

Art. 7526 Ø 10 ●

Bracci raffreddati ad acqua / Water-cooled arms / Bras refroidis par eau / Wassergekühlt Arme / Brazos refrigerados por agua

Art. 7512 L=150 mm
 Art. 7513 L=250 mm
 Art. 7514 L=350 mm
 Art. 7515 L=500 mm
 Art. 5211/2 ●

Art. 5210/2 ●
 Art. 5210/C ◆

Art. 5211/2 ●
 Art. 5211/C ◆

Art. 5212/2 ●
 Art. 5212/C ◆

Art. 5214/C ●
 Art. 5214/C ◆

Art. 3833 ●

Art. 3835 ●

● Coppia / Pair / Couple / Paar / Par ◆ Set 12 pezzi / Set of 12 pcs / Kit 12 Stück / Lot de 12 pièces / Set de 12 piezas

Bracci con elettrodi caps / Arms with cap electrodes / Bras avec caps électrodes / Arme mit Elektrodenkappen / Brazos con electrodos caps

Art. 5001 L=125 mm
 Art. 5003 L=250 mm

Art. 5004 L=350 mm
 Art. 5005 L=500 mm

Art. 5085 L=350 mm

Art. 5201

Art. 5202

Art. 5203

Art. 5204

TECNA può variare, senza preavviso alcuno, i propri prodotti. - Specification subject to change without notice. - TECNA se réserve le droit d'effectuer des changements sans préavis. - Technische Aenderun